

Reporting your repairs

– before you contact us

This booklet can be made available in
large print, on tape, in Braille
and in other languages

Reporting Your Repairs

The flowchart below shows the processes involved when a repair is reported.

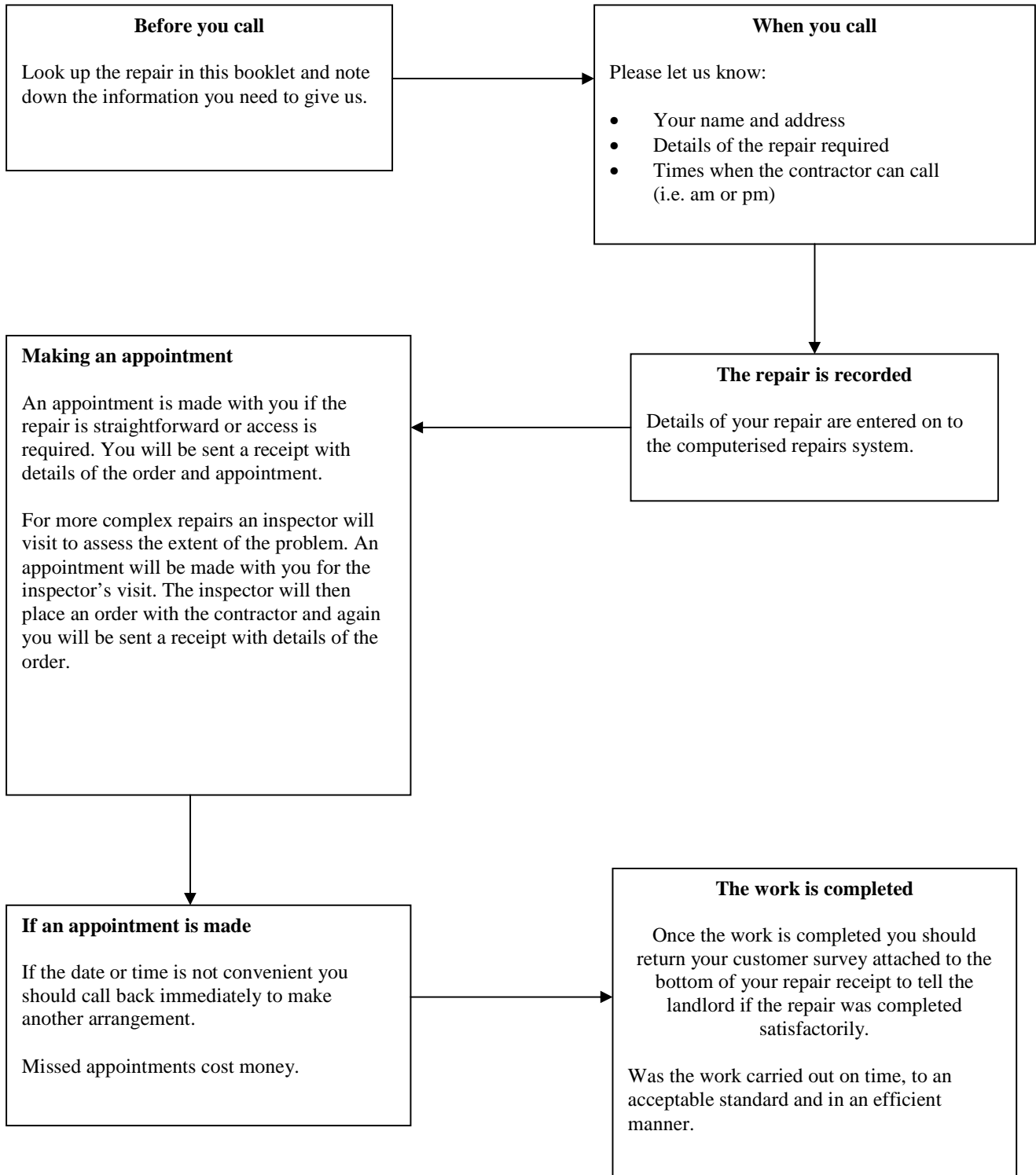

When you report your repair we will ask you to describe the problem, this guide has been designed to help you identify the work you would like us to carry out. It looks at the different types of repair, and gives important hints on what you need to know when reporting a repair.

For each type of repair, some technical information is given. There are also a number of illustrations, which will help you describe the fault.

The guide has also been designed to give you examples of the sort of questions you will be asked and the information we would like from you when you report a repair.

Kitchen

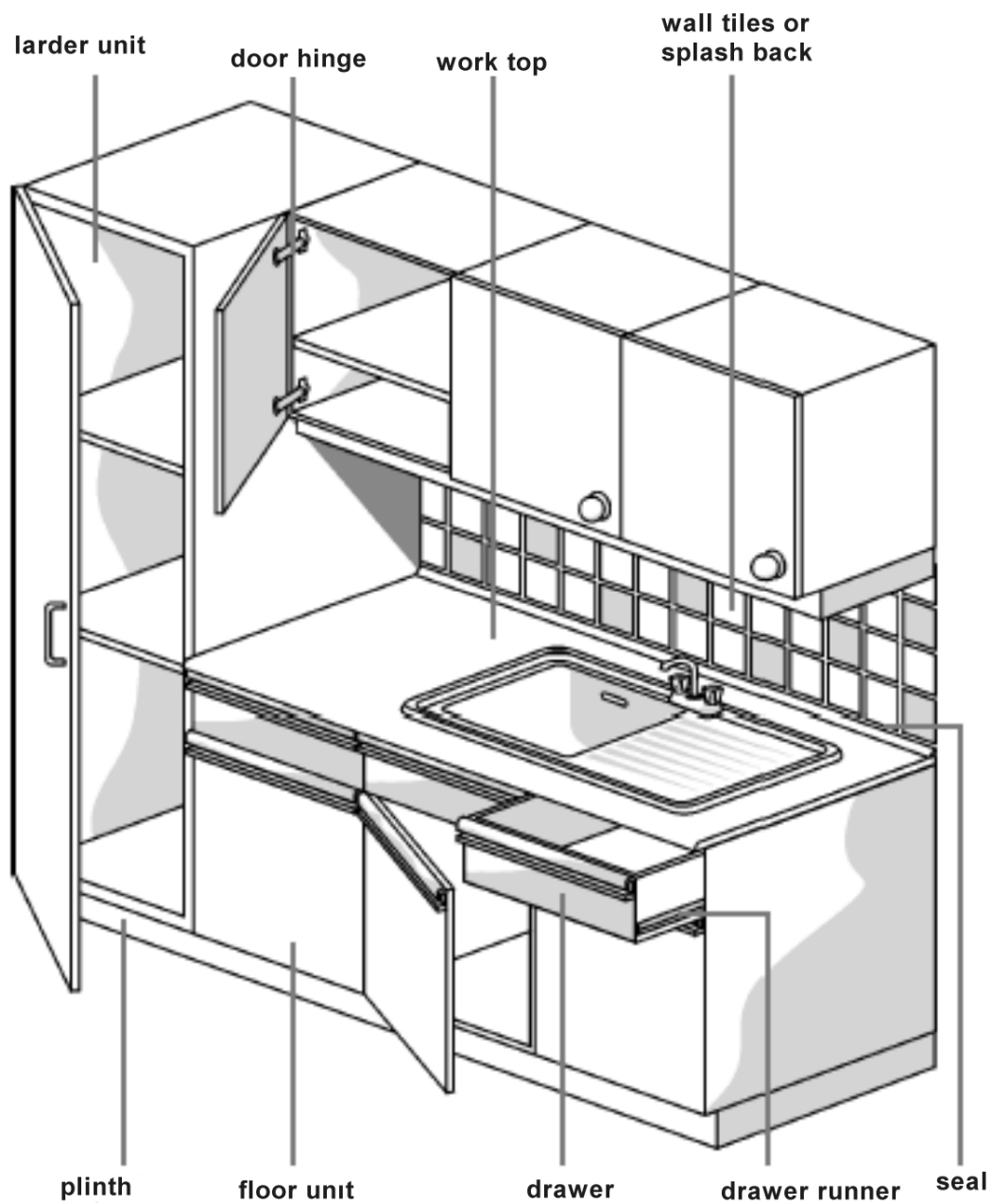

Before you contact us...

- Try to stop the leak causing more damage.

- Try to clear it yourself using a plunger. See Useful Hints for help.
- Stop others using sink while blocked.

Tell us...

Damaged cupboard

- Which unit is affected? (a corner unit, floor or wall unit, with single or double doors)
- What part is faulty? (see diagram opposite)
- In what way is it damaged?
- Do you think it can be repaired or will it need to be replaced?
- What is it made of? (wood, plastic or metal etc)
- What colour and size is it?

Sink unit leaking

- Where is leak coming from?
- (pipe, tap or waste pipe/trap. See diagrams)

Sink blocked

- Are other outlets affected?
- Is washing machine blocked?
- What caused the blockage?

Damaged wall tiles

- Where are tiles?
- Are they broken, loose or missing?
- How many are affected?
- What size and colour are they?

Kitchen

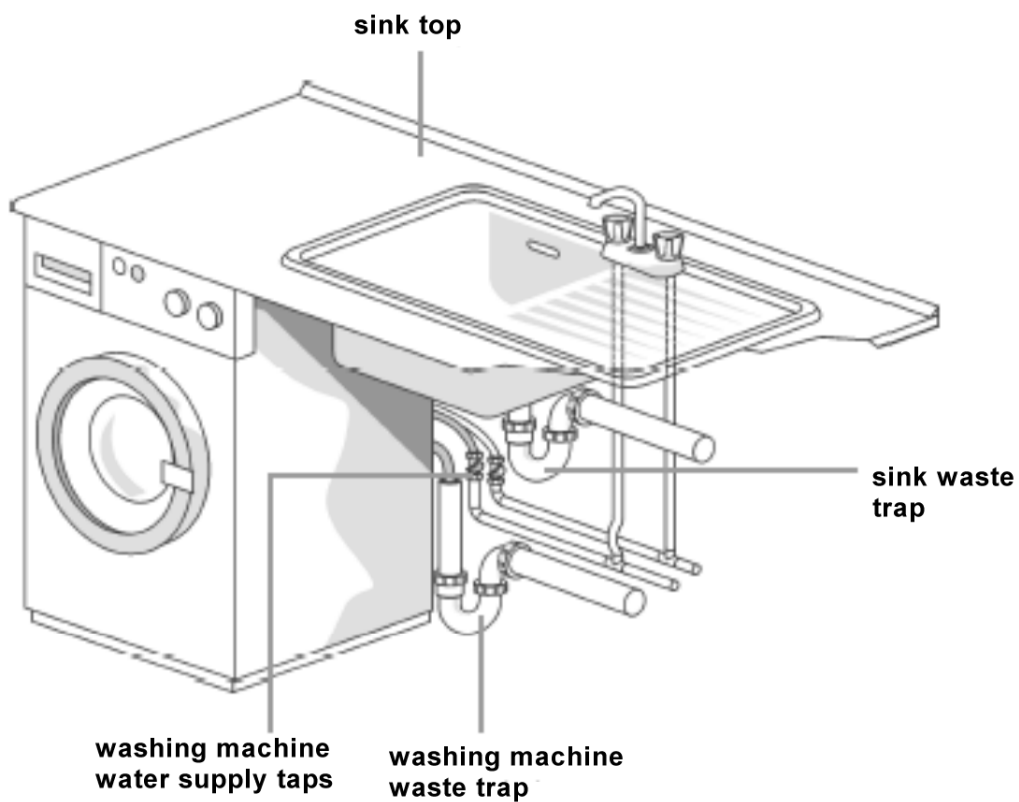

**'p' trap with
washing machine
connection**



Before you contact us...

Tell us...

Seal gone around sink

Sink tap dripping

- What type of tap is it? (see diagrams on page 10)

Tap loose

- What type of tap is it? (see diagrams on page 10)

Sink plug/chain required

- What happened to the plug and chain?

Washing machine blocked

- Do you know what caused the blockage?

Bathroom and WC

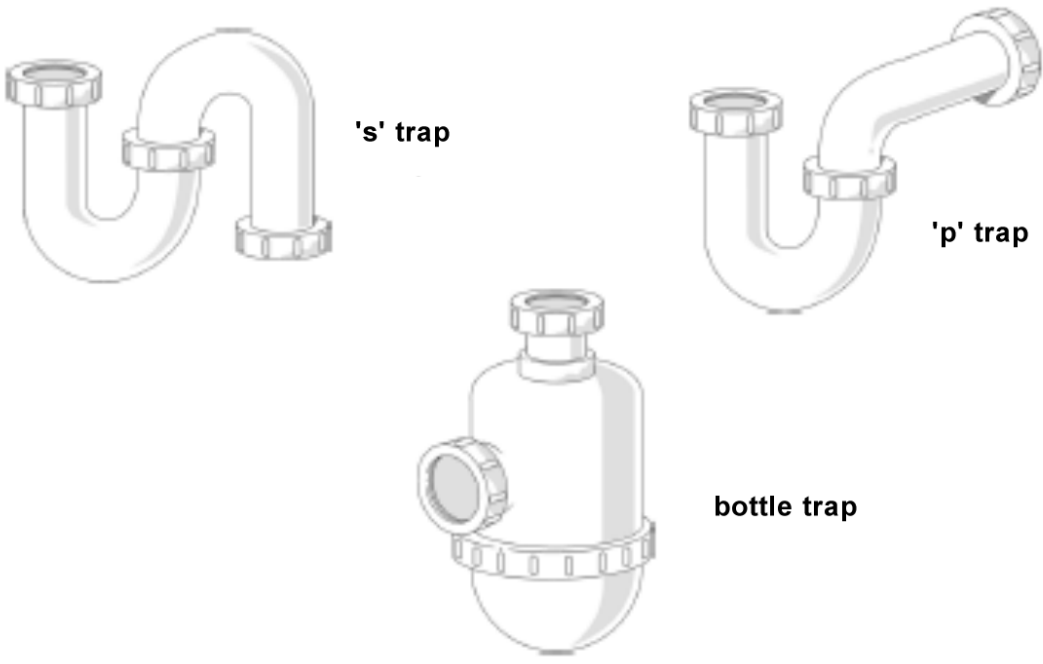
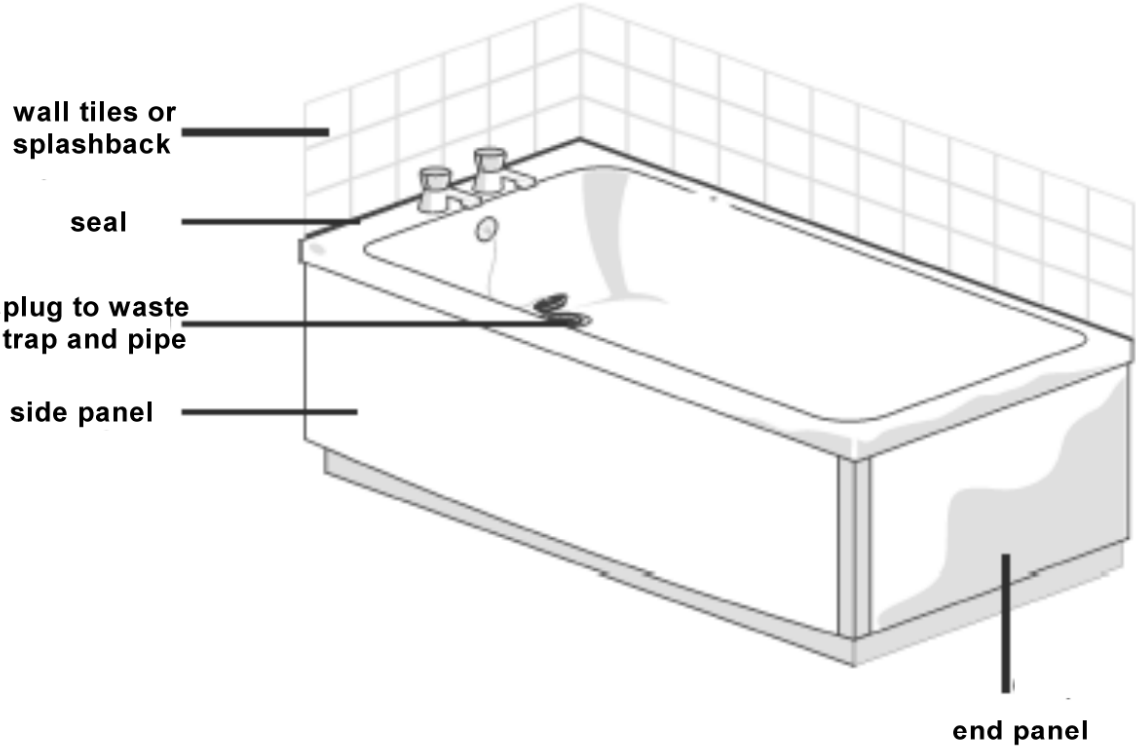

Bathroom and WC

Before you contact us...

- If water is near electrics, do not touch.
Turn electricity off at consumer unit main switch.
- Stop leak causing more damage.

- Can you clear blockage yourself?

Tell us...

Bath/basin water leaking

- Are electrics affected?
- Where is leak?
(bath or basin)
- What is affected?
(waste pipe/trap, pipe or tap).
- If pipework is affected, is it hot or cold supply pipe, or waste trap?

Bath/basin blocked

- What caused the blockage?

Bath or basin damaged/ broken

- What is damaged?
(bath or basin)
- What is affected part made from?
(metal, plastic or china etc)
- If a bath panel is affected, which panel (side or end panel) and what is it made from (hardboard or plastic)?
- Does it need to be replaced or refixed?

Bathroom and WC

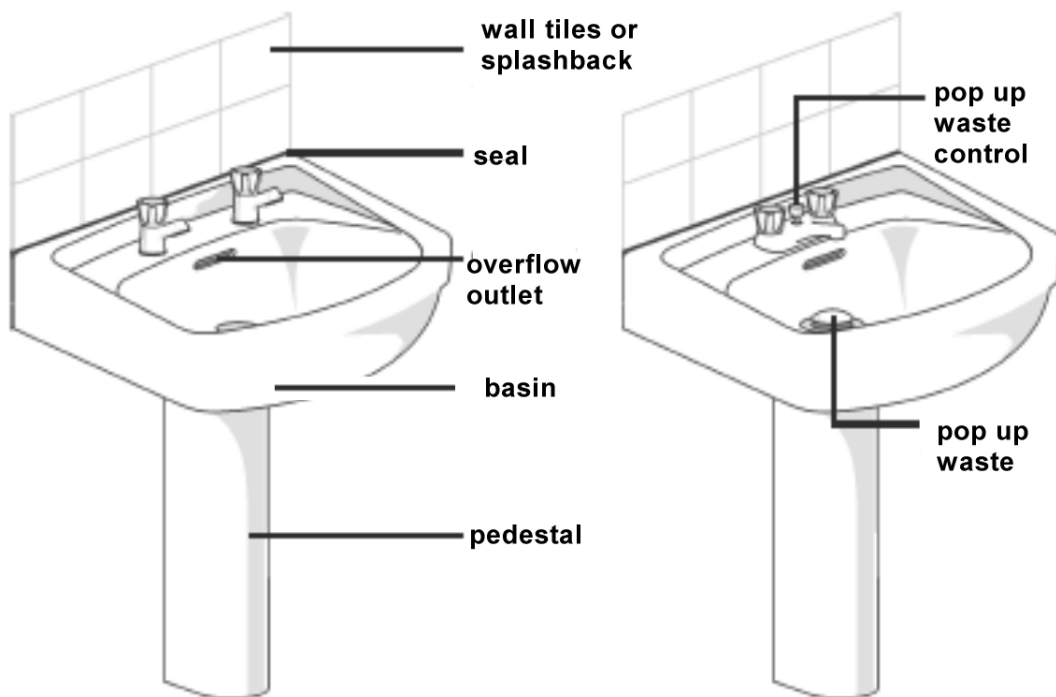

Bathroom and WC

Before you contact us...

Tell us...

Damaged wall tiles

- Where are tiles?
- Are they loose, broken or damaged?
- How many are affected?
- What size and colour are they?
- How did it happen?

Bath panel loose

- Which panel is affected? (side or end panel)
- What is it made from? (hardboard or plastic)

Seal gone around bath

Seal gone around basin

Bath tap dripping

- What type of tap is it?

Basin tap dripping

- What type of tap is it?

Tap loose

- Bath or basin tap?
- What type of tap?

Plug/chain required

- Is it on bath or basin?

Bathroom and WC

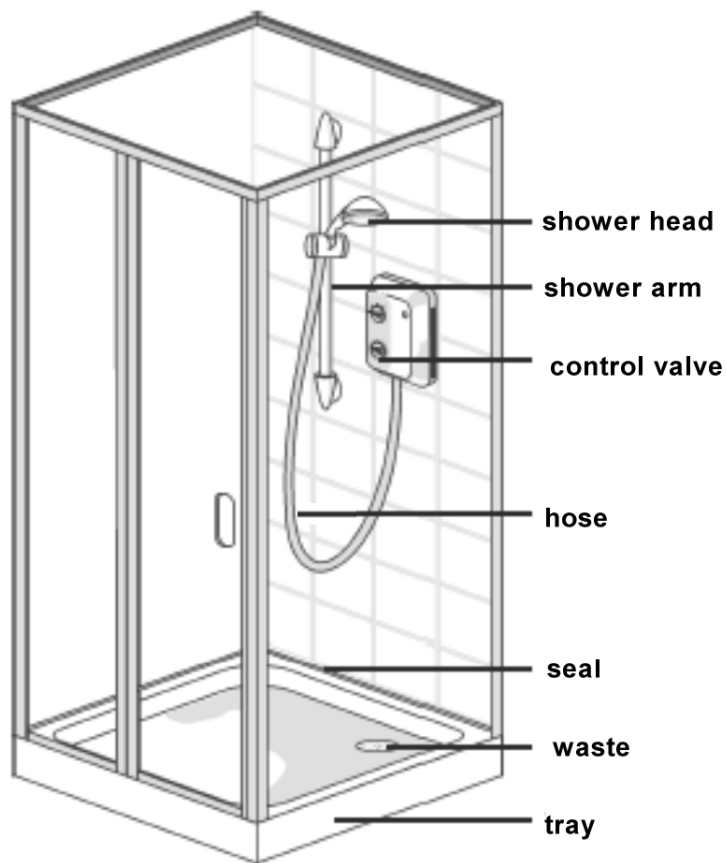

ceiling pull cord
switch for electric shower



electric shower

bath/shower
mixer tap



Bathroom and WC

Before you contact us...

Bathrooms and WCs

- If it is your own shower, this is your responsibility.
- If electric, check power is switched on (by cord or switch) and controls are set correctly.

- If it is your own shower curtain, this is your responsibility.

Tell us...

Seal gone around shower tray

Shower tray broken

- What is it made of? (ceramic or plastic)

Shower not working

- What type of shower is it? (electric or connected to the central heating).
- What is happening? (no water, or only hot or cold water)
- Do you have hot water in rest of home?
- Can you see a make or model number on shower?

Shower curtain damaged

Shower blocked

- What is causing blockage?

Shower switch broken

Shower hose broken

- How did it happen?

Shower arm broken

- How did it happen?

Bathroom and WC

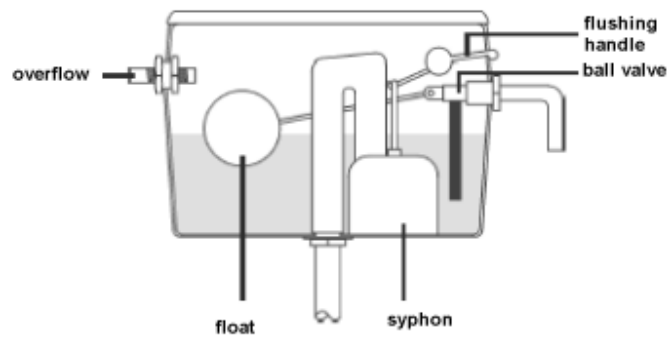
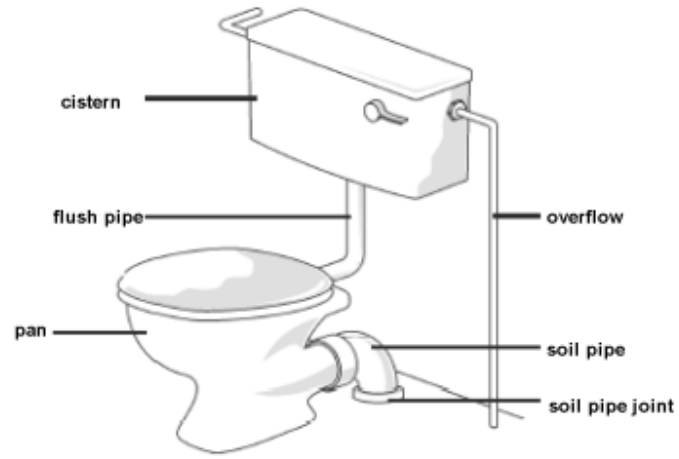

Bathroom and WC

Before you contact us...

- Try to stop leak and any damage it is causing.
- If serious, turn off water at stopcock and gate valves from cold water tank.
- Open all taps to drain water from system. Turn off heaters affected.

- Has water company said that water would be going off?
- You can use a bucket of cold water to flush until problem is fixed.
- If cistern is not filling, lift lid and see if anything is stopping the float from working. Try moving the float up and down to see if it will fill.

Tell us...

Damaged wall tiles

- Are the tiles loose, broken or damaged?
- How many are affected?
- What size and colour are they?
- How did it happen?

Cubicle door not working

- Is it broken or stuck?

WC leaking

- Where is leak? (pan, cistern, overflow, supply, flush or waste pipe or pipe joint.
- If leak is from cistern, is it high or low level cistern?
- Is affected part loose, cracked or broken?
- Is it your only WC?
- Is it a coloured WC or white?

WC will not flush

- Is the handle or chain moving properly?
- Is the float still working?

Bathroom and WC



'p' type waste trap



's' type waste trap



low level cistern

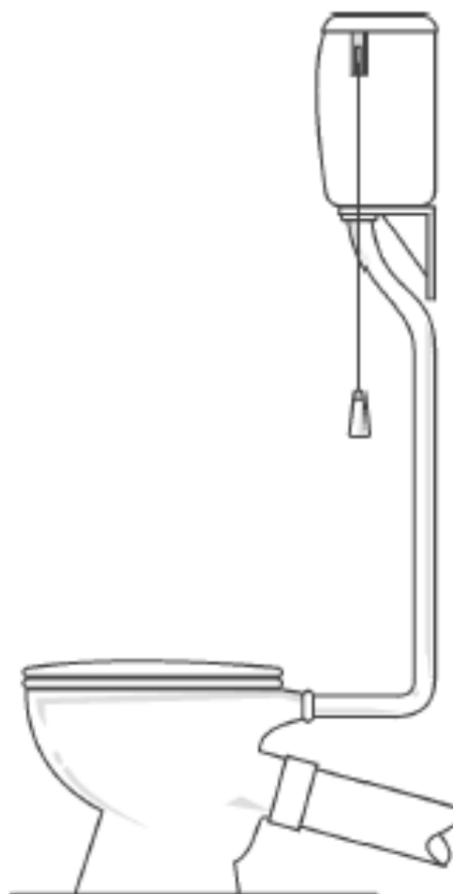

high level cistern

Bathroom and WC

Before you contact us...

- As a temporary solution, tie float in the up position, thus closing the ball valve

- Try unblocking it yourself by removing excess water into a bowl, and using a toilet brush or plunger (without metal disk).

Tell us...

Overflow running

- Does the overflow run outside?
- Is the cistern flushing?
- Is the float working?
- Is the overflow running continuously?

Seat damaged

- Is it broken, damaged or missing?
- What is it made from? (plastic, wood etc)
- What colour is it?

WC blocked

- What caused blockage?

Soil stack blocked

- Do you live in a house or flat?
- If a flat, which floor are you?
- Is your WC causing the blockage?

Water System

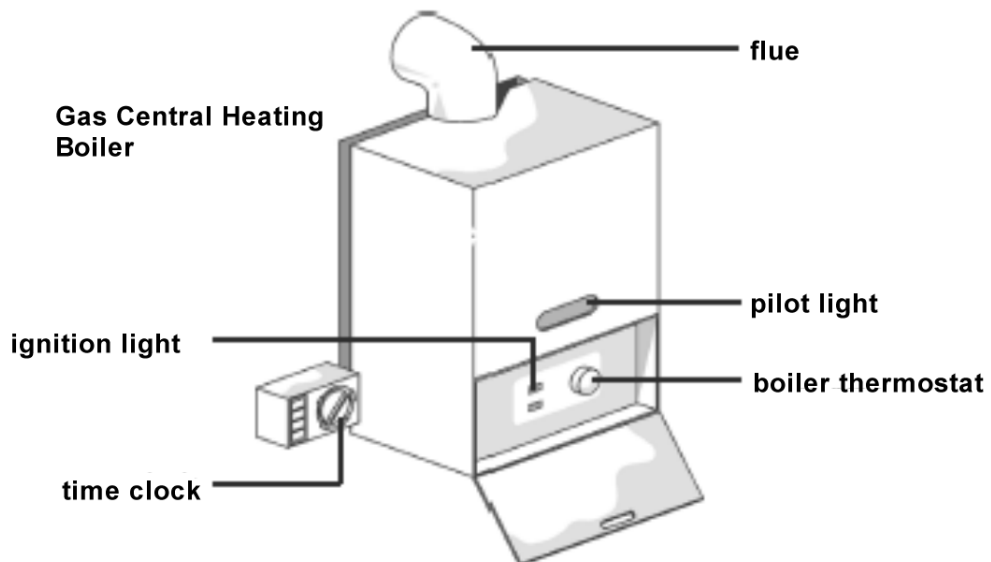
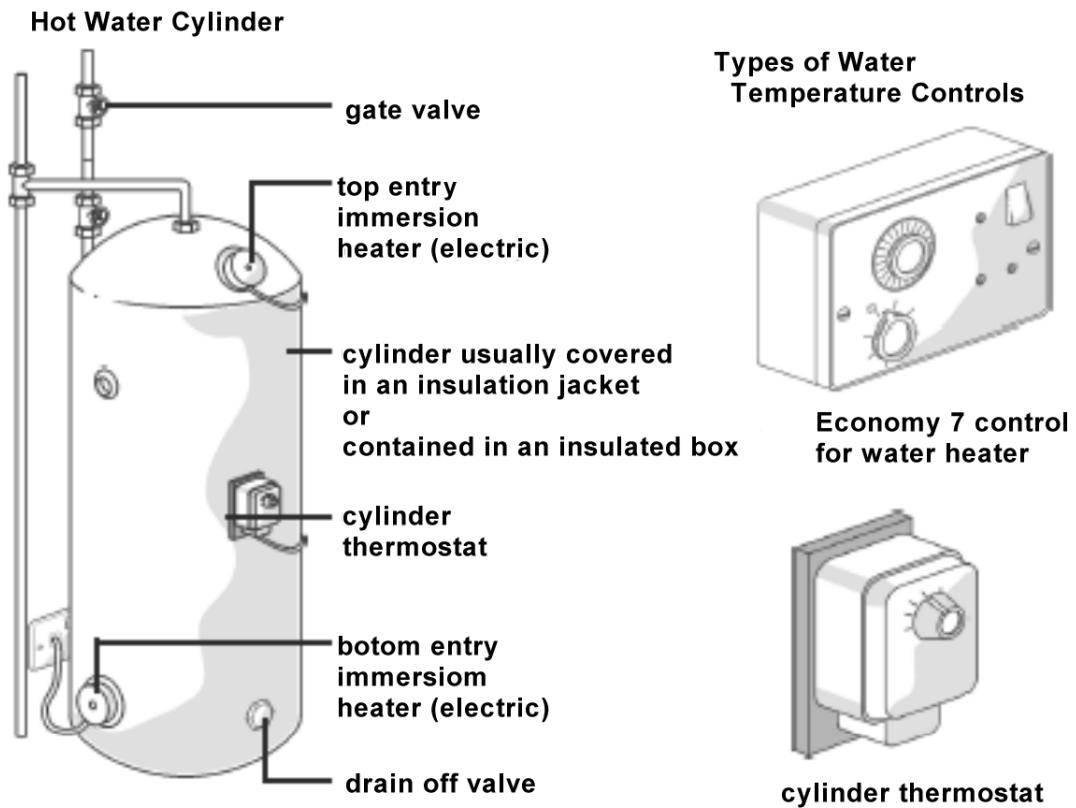

Water System

Before you contact us...

- If gas, check time clock controller is set for hot water and timer is set correctly.
- If electric, is there a power cut?
- Are neighbours affected? If so, contact your electricity company (see under 'electricity' in Phone Book).
- If coin or credit meter has it run out of credit?

Tell us...

No hot water

- What heats water? (gas, electric, or solid fuel)
- If electric, are other electrical facilities working?
- Are heating controls set correctly?
- Is room heating still working?
- Do you have an alternative source of hot water? (immersion heater or gas heater etc)
- Do you have a hot water cylinder?

Electrical

Electricity Meter Cupboard

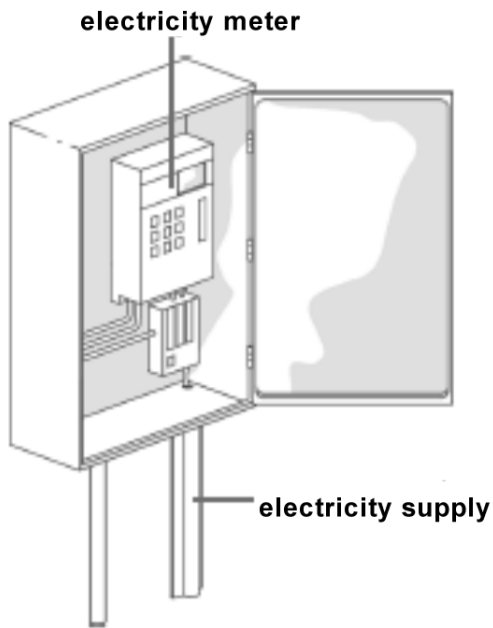

Electical Consumer Unit

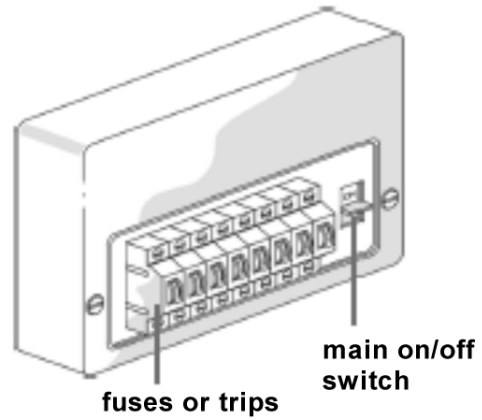

trip switch
- replaces fuses
in a modern
consumer unit

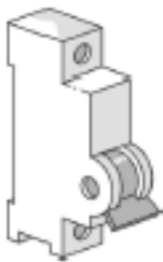
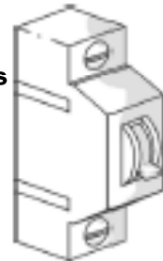

trip switch

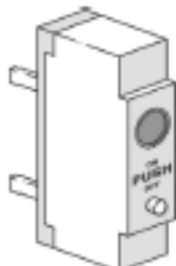

micro
circuit
breaker

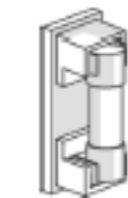

cartridge fuse



rewirable fuse

Fluorescent Light Fitting

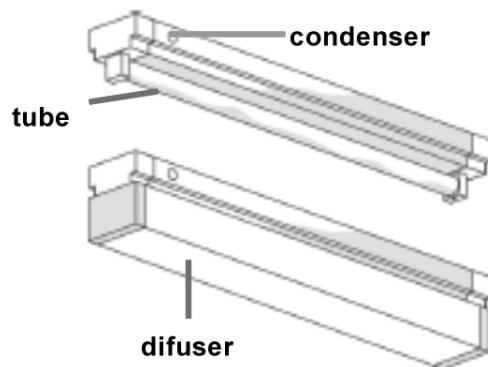

Before you contact us...

- If you have a coin or credit meter, check that it has credit on it.
- See if trip switch is activated or a fuse has blown on consumer unit. (see page 20 for help)
- Are your neighbours affected?
- If so, contact your electricity board (under 'electricity' in the Phone Book).

- Do not touch fitting.
- Turn electricity off at consumer main switch.

- See if trip switch is activated or fuse has blown on consumer unit.
- Has bulb blown?
- Are power sockets working?

Tell us...

No power at all

- Is yours the only property affected?
- Has trip switch been activated or a fuse blown on the consumer unit?

Electrical fitting smoking

- What fitting is it? (light, plug etc)
- Where is it located?

Light circuit failed

- Are power sockets working?
- How many lights are affected?
- Is light fitting causing the problem? (the pendant, batten holder, wall or ceiling switch etc.

Fluorescent tube not working

- What is the problem? (tube flickers, broken etc)

Electrical

**single
socket**



**double
socket**

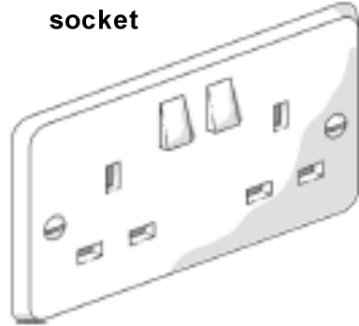

**cooker
socket**

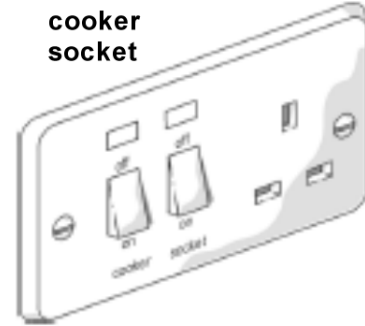

**ceiling pull
switch**



pendant lamp holder

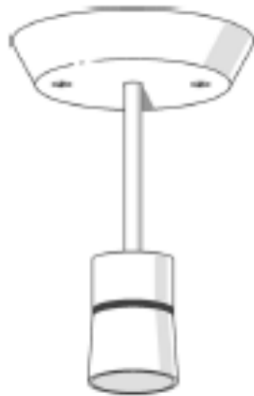

**batten lamp
holder**



smoke detector/alarm

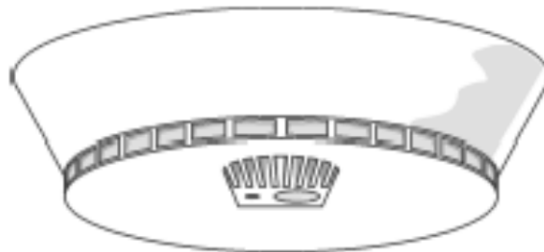

Before you contact us...

- Is it appliance rather than power socket that is faulty?
- Is trip switch activated or a fuse blown in the consumer unit? See page 20, for help).
- Is there no power at all in your home? If so, see "No power".

- Tenant's own appliance is tenant's responsibility.
- Is it power socket rather than appliance that is faulty?
- Has fuse blown in the plug? If so renew it with a suitably rated fuse.
- Is trip switch activated or a fuse blown in the consumer unit?
- Is there no power at all in your home? If so, see "no power".

- If it is battery operated, check batteries.
- If you have a warden, contact them.

Tell us...

Plug socket not working

- Are other power sockets not working?
- Is trip switch activated or a fuse blown in a consumer unit?

Appliance not working

- Are other power sockets working?
- Is trip switch activated or a fuse blown in consumer unit?

Smoke detector defective

- Is it battery operated?
- Where is the smoke detector?
- What appears to be problem?

Heating - Gas, and Electrical

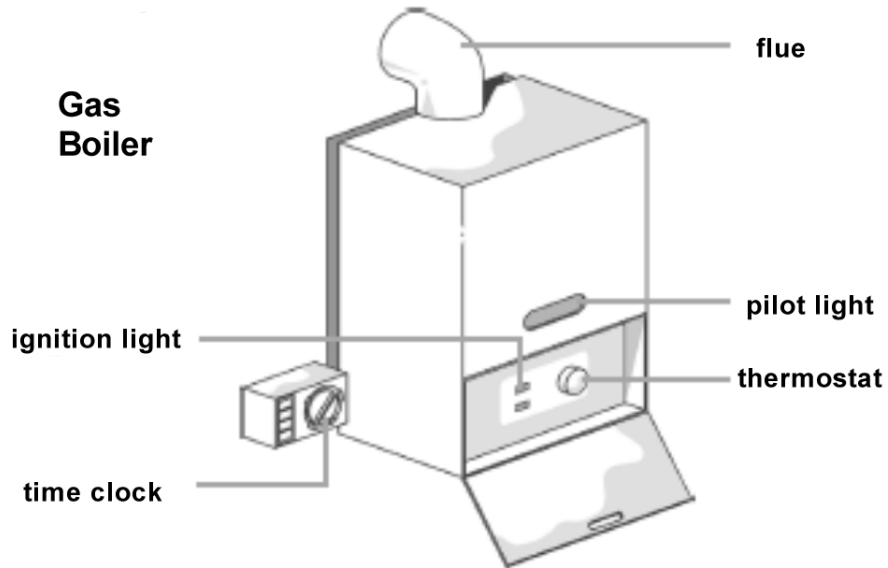

Heating Controls

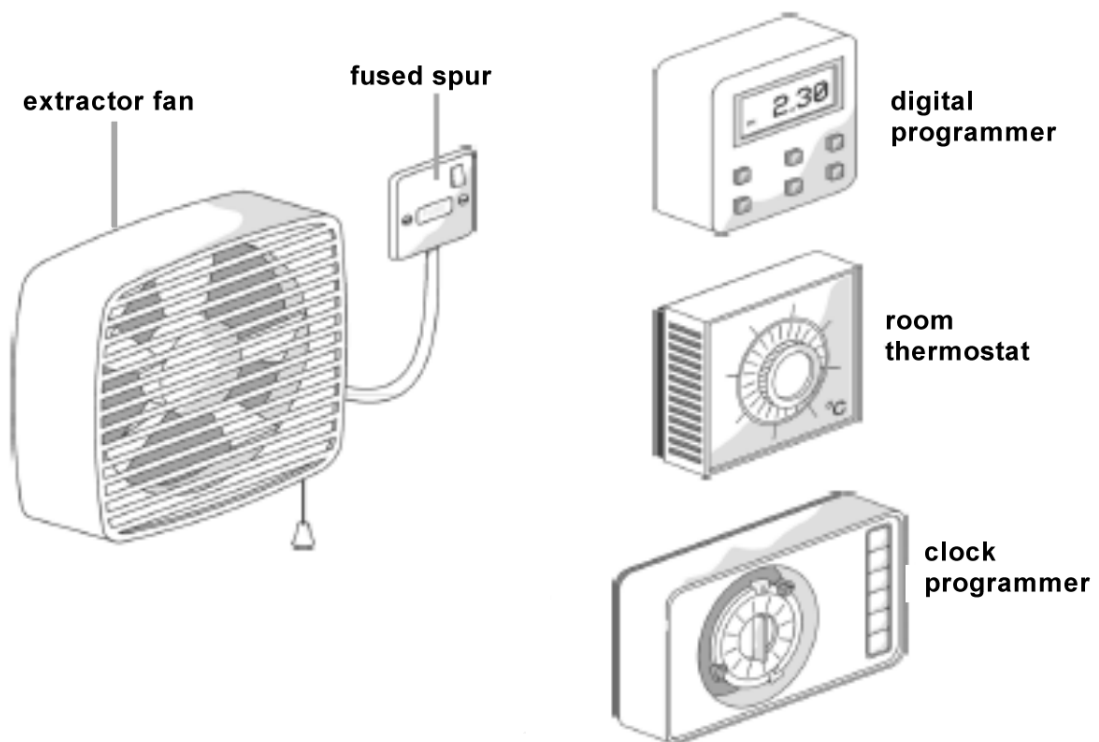

Before you contact us...

- Is fan switched on?

- If electric, check that power is still on, and that meter is still in credit.
- If gas, check that pilot light is on.
- Check that boiler thermostat is set correctly (usually between 18°C and 22°C. See diagram opposite).
- Check that clock or digital timer is set.

- Check that room thermostat is set correctly (usually between 18°C and 22°C).
- Are other flats affected?
- If you have a warden or caretaker, contact them.

- Check that thermostatic valve is turned up enough (See diagram on page 26).
- Try bleeding radiator.

Tell us...

Extractor fan faulty

- Where is fan?
- What type of fan is it?

Central heating boiler faulty

- Is it your only source of heat?
- Do you have hot water?
- Can you see manufacturer's name and what model it is?

Communal heating faulty

- Is this your only source of heat?
- Is there any hot water?

Radiator not heating up

- Is thermostatic valve turned up enough?
- How many radiators are affected?
- Have you tried bleeding radiator(s) affected?

Heating - Gas, and Electrical

Storage Heater

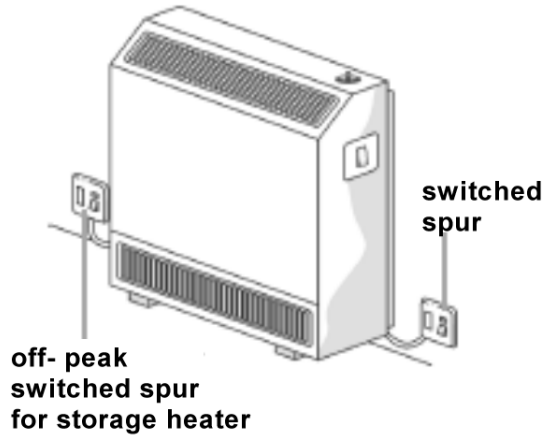

Convactor Heater

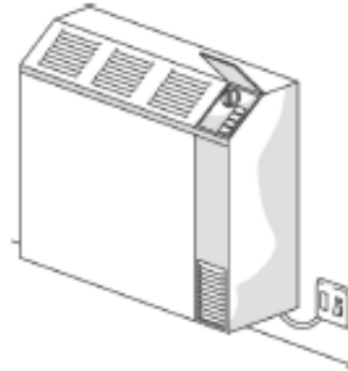

radiator panel

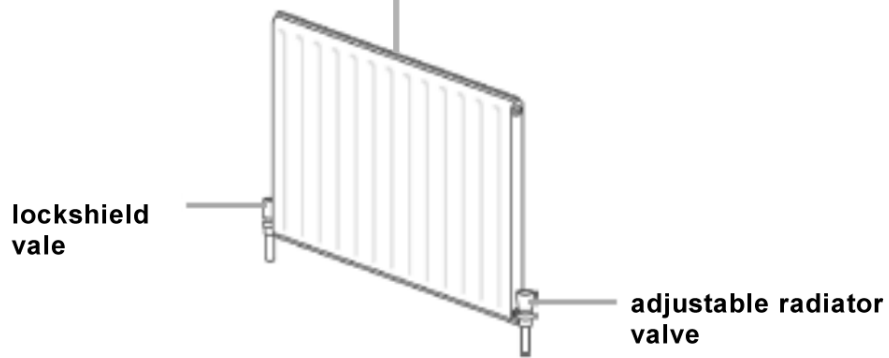

central heating pump

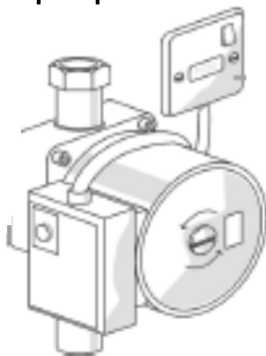

manual radiator valve

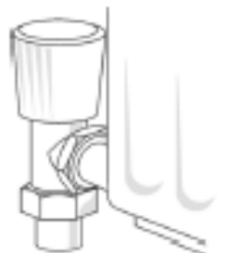

thermostatic radiator valve

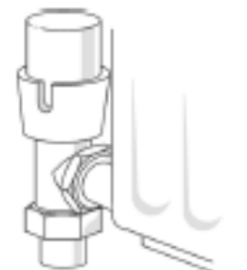

Heating - Gas, and Electrical

Before you contact us...

- Try to stop leaking causing damage.
- Turn radiator valve off.

- If gas leak, do not smoke, use matches, or turn electrical switches on or off. Open windows. Follow emergency action.
- Turn off any appliances that are causing fumes.

- Make sure heater is turned on at socket.
- Check thermostat is set correctly.
- If no power in rest of home follow the “no power” advice.

- Check thermostat is set correctly.
- Check fuse to the switched spur.

Tell us...

Radiator leaking

- Where is leak coming from? (see diagram on page 26)

Fumes appear in room

- What is causing fumes?
- Has flue been cleaned recently?
- If the heating system is the cause, can you see the manufacturer’s name and the model?

Storage heater defective

- How many heaters are affected?
- Where are they?
- What appears to be the problem?
- Can you see manufacturer’s name and model number?

Radiant/convector heater faulty

- What appears to be the problem?
- Can you see the manufacturer’s name and model?

Internal Doors

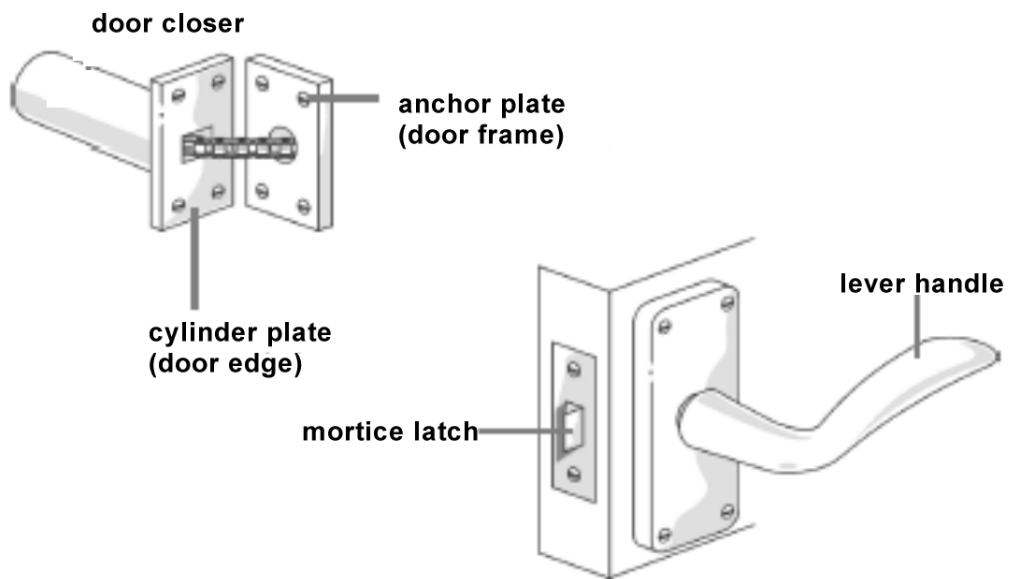
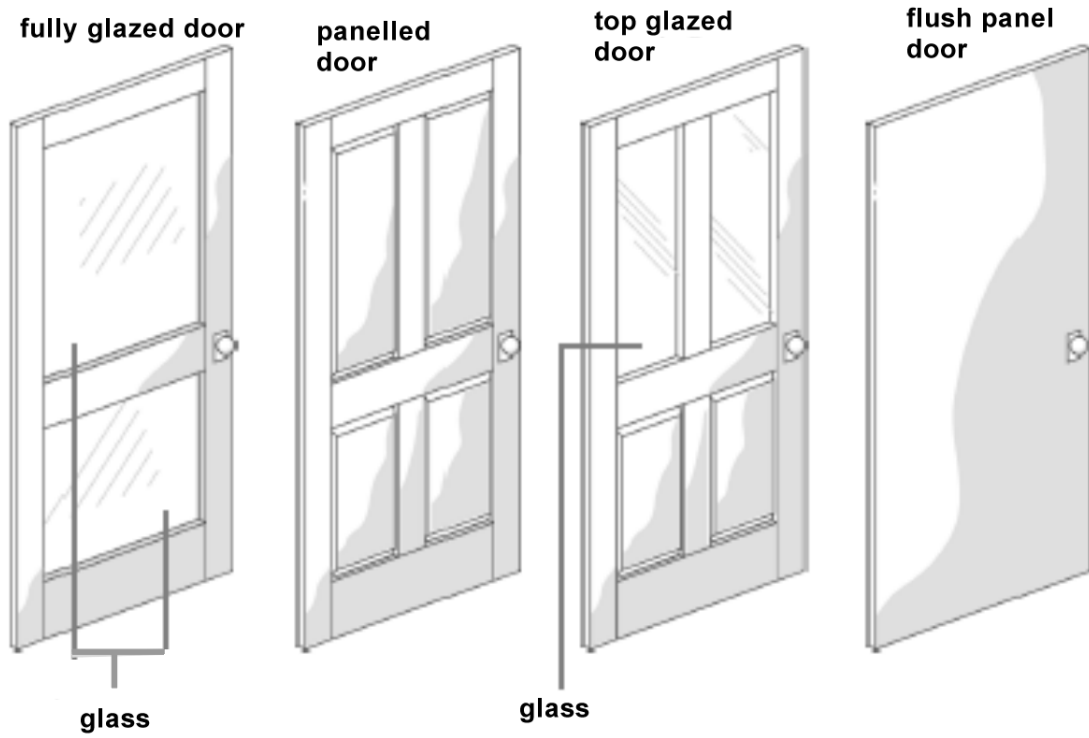

Before you contact us...

Tell us...

Door sticking/jamming

- Where is door?
- What type of door is it? (see diagrams on page 28)
- What appears to be the problem?

Door Damage

- Where is door?
- What type of door is it? (see diagrams on page 28)
- What appears to be the problem?
- How did it happen?

Door latch defective

- What type of latch fitting is it?
- Where is door?
- What is wrong with it?
- How did it happen?

External Doors and Windows

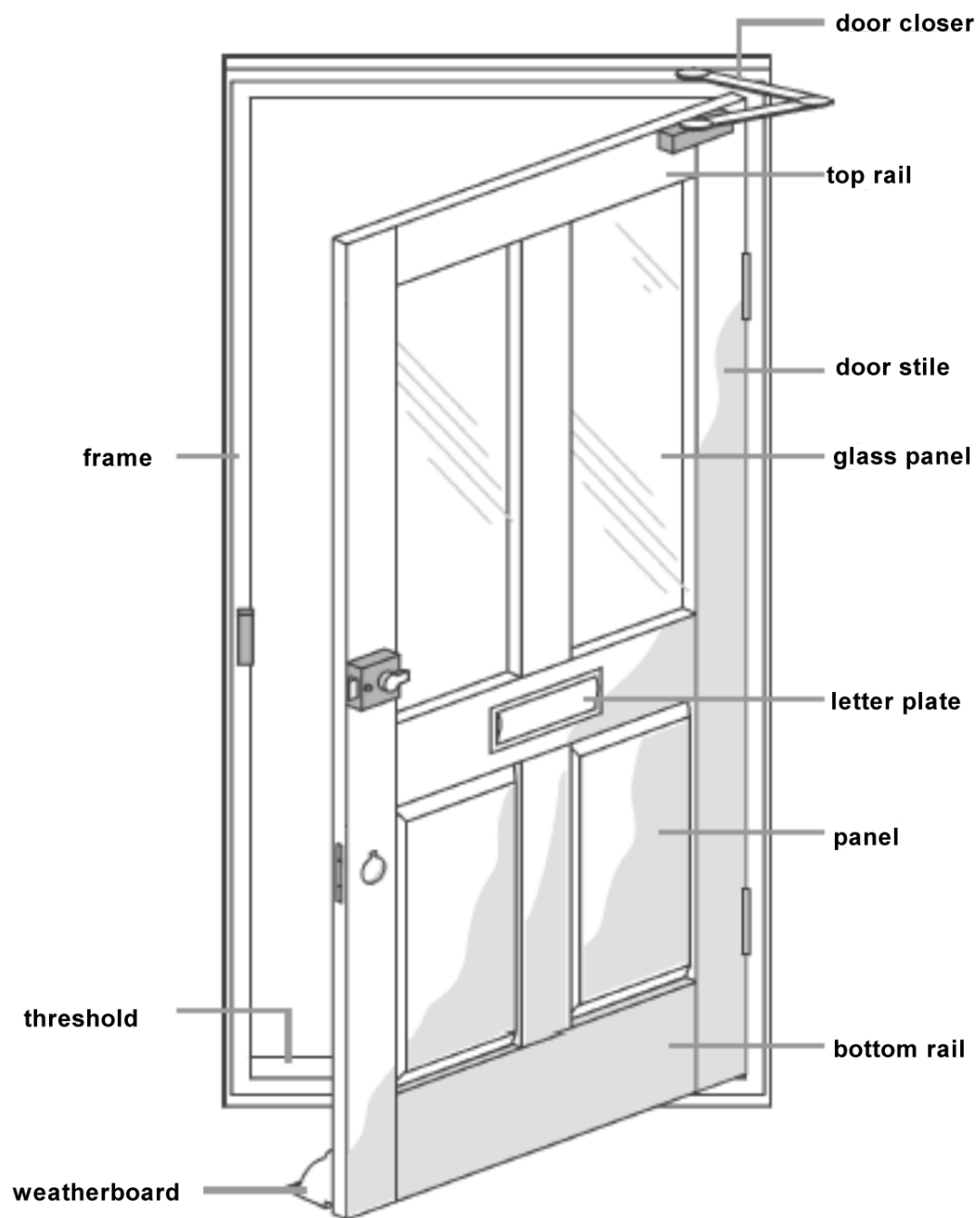

External Doors and Windows

Before you contact us...

Tell us...

Door jammed

- Is it front or rear door?
- What type of door is it?
- What is door made of? (wood, metal or plastic etc)
- Is door jammed open or closed?
- Can you still get in and out of your home?

Door frame damaged/rotten

- Is door or frame affected?
- Is it front or rear door?
- What type of door is it? (see diagrams on page 32)
- What is door made of? (wood, metal or plastic etc)
- What is wrong with it? (damaged or rotten)
- Is home insecure as a result of this problem?

Threshold rotten/needs repair

- What type of door is it? (see diagrams on page 32)
- What is it made from? (wood, metal etc)
- What is wrong with it? (rotten, broken etc)

External Doors and Windows

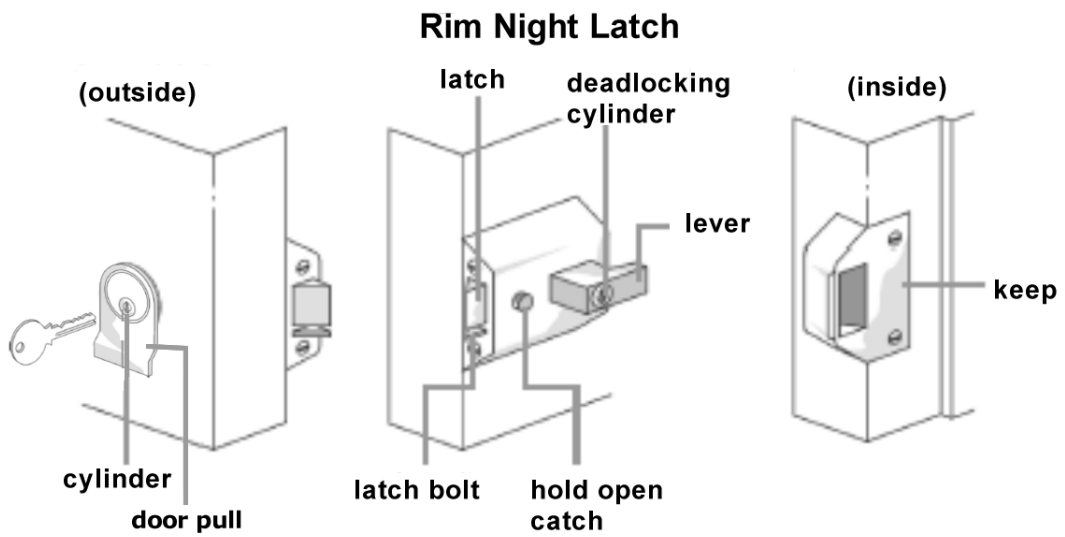
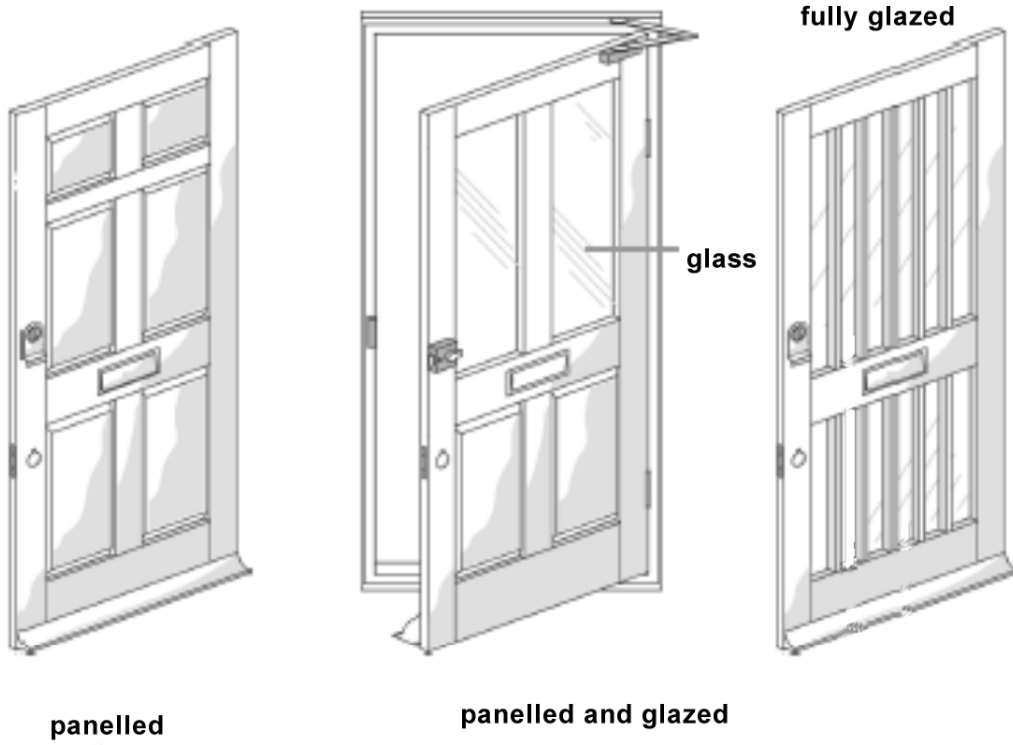

External Doors and Windows

Before you contact us...

Tell us...

Weatherboard rotten/broken

- What type of door is it? (see diagrams on page 32)
- What is it made from? (wood, metal or plastic)
- What is wrong with it? (rotten, broken etc)

Glass damaged

- What type of door is it?
- If fully glazed which panel(s) is damaged?
- Is it your own door or a communal one?
- Is it front or rear door?
- Is it single or double glazed?
- What type of glass is it? (clear, wired or obscure)
- Is your home secure?

Draught coming around door

- Where is the draught coming from? (between wall and frame, around door or under door)
- Is there any draught proofing around door?

Rain coming in under door

- Does the door have a weatherboard?

External Doors and Windows

Mortice Deadlock

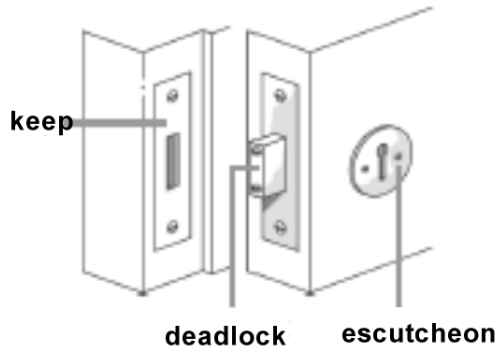

Rim Lock

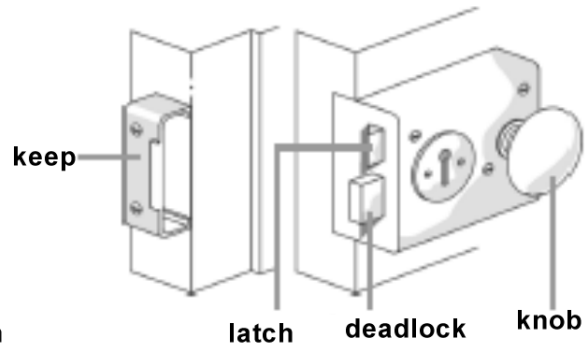

Mortice Claw Bolt Deadlock - sliding door

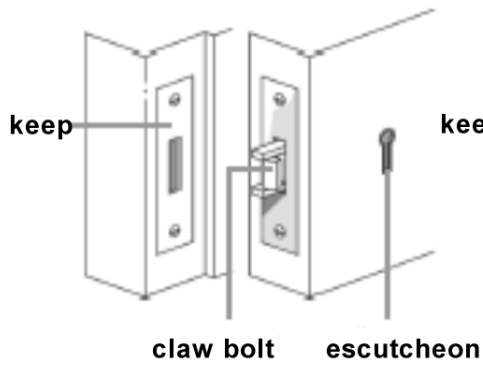

Internal Door Latch

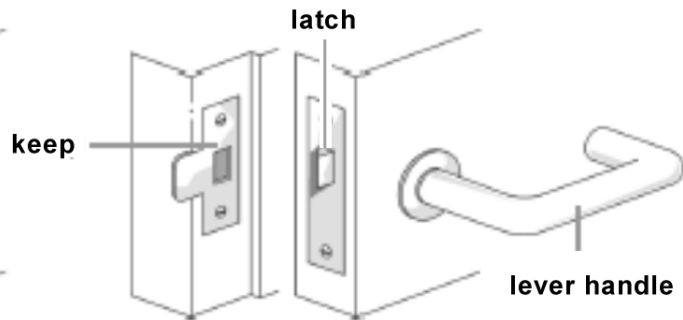

Mortice Sash Lock

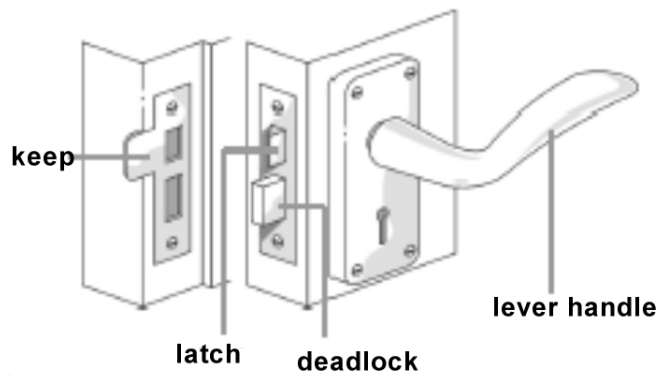

External Doors and Windows

Before you contact us...

- Tenant's own locks are your own responsibility.

- This is usually your own responsibility.

- Tenant's own fittings are your own responsibility.

Tell us...

Door lock not working

- What type of lock is it? (see diagrams on page 34)
- What is wrong with lock? (lever handle faulty, spring worn out, striking plate out of place or lock fitting into keep etc. See diagrams on page 34)
- Which door is affected?
- What is door made of? (wood, metal or plastic)
- Is your home secure?

Keys lost/locked out

- Are you locked out of your home?
- What type of lock is it? (see diagrams on page 34)
- Where is door? (front, rear, patio or store)

Ironmongery missing/not working

- What fitting is it? (letterplate, handle, chain, door viewer, house numbers etc)
- Is door not closing properly?
- Is your home insecure?

External Doors and Windows

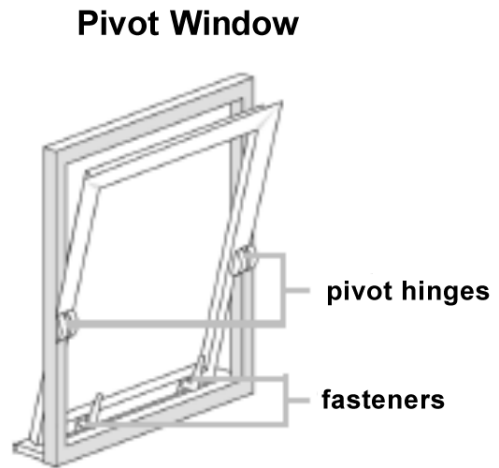
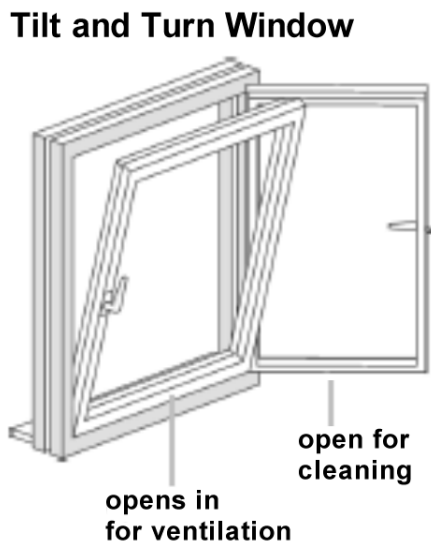
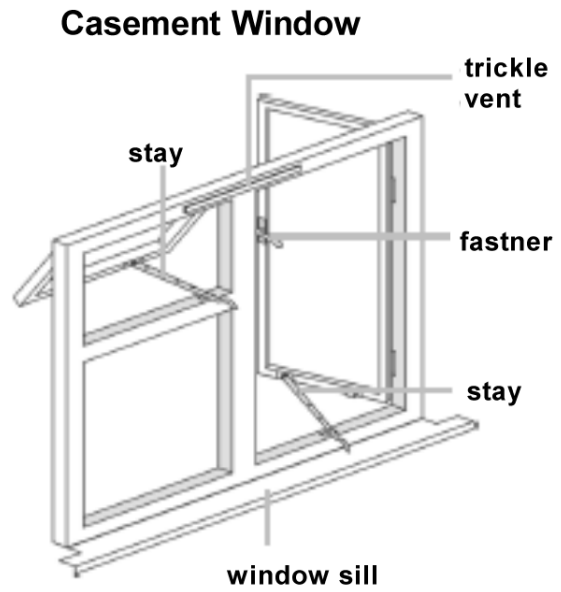
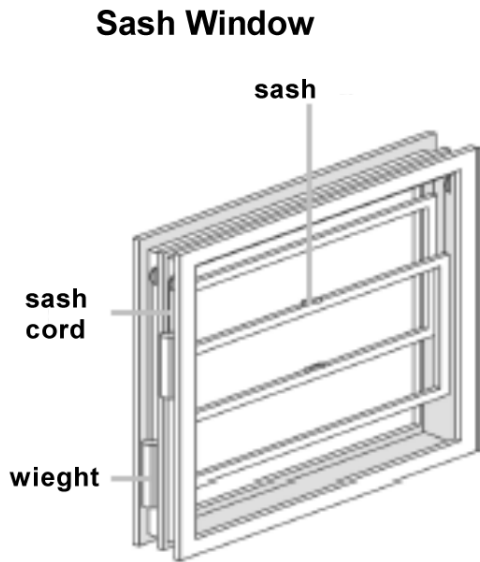

External Doors and Windows

Before you contact us...

- If you can do it safely, remove any loose broken glass which could be dangerous to others, and wrap it in newspaper before binning it.

Tell us...

Glass damaged

- Is it single or double glazed?
- Where is window? (which floor of the building, a communal window or one to your home)
- What type of glass is it? (clear, wired or obscure)
- What is window frame made of? (wood, metal or plastic)
- Is your home secure?

Window frame jammed

- What is frame made of? (wood, metal, or plastic)
- What type of window is it? (sash, pivot or tilt window etc. See diagrams on page 36)
- What is causing the problem? (rotten wood, hinges or sash cord broken etc. See diagrams on pages 36 and 38)
- Is your home secure?

External Doors and Windows

Sash Fasteners

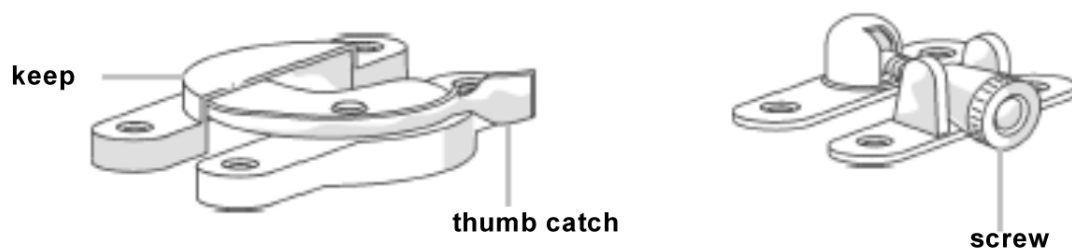

Hook Casement Fastener

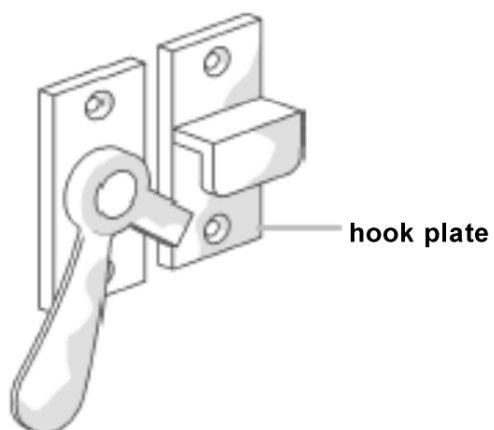

Window Restrictor



Casement Stay

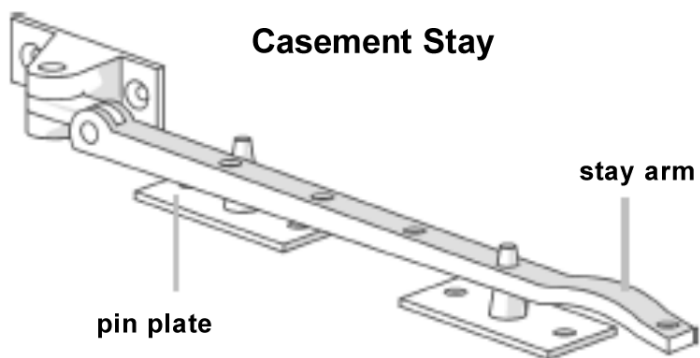

External Doors and Windows

Before you contact us...

Tell us...

Ironmongery defective

- What type of window is it? (sash, pivot or tilt window etc. See diagrams on page 36)
- What is frame made of? (wood, metal or plastic)
- What part is defective? (stay, catch, fastener or lift etc. See diagrams opposite and on page 38)
- Is your home insecure?

Communal Facilities



door entry call unit

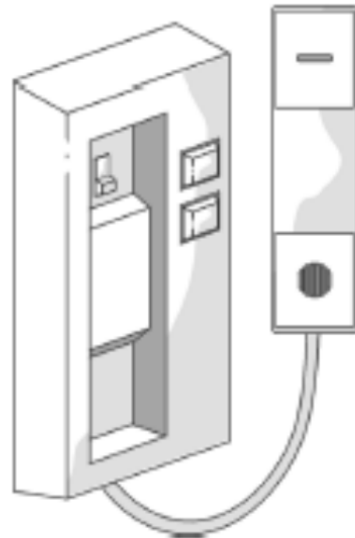

door entry phone

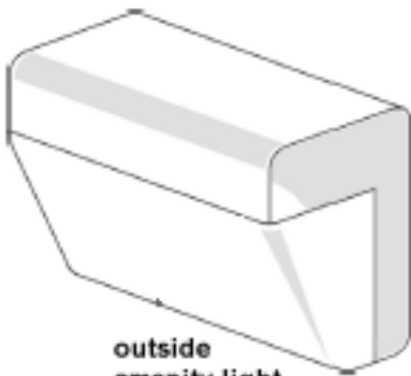

**outside
amenity light**

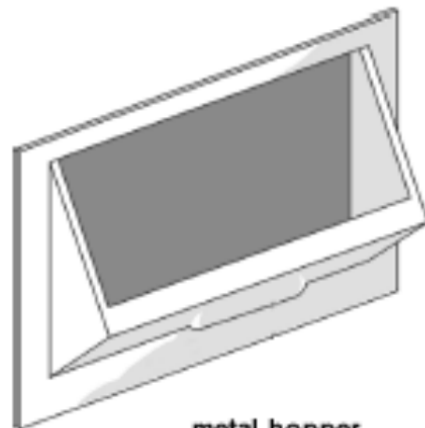

**metal hopper
to refuse chute**

Communal Facilities

Before you contact us...

Tell us...

Door entry faulty

- Has whole system failed, or is only your home affected?
- Is fault at entrance or your phone?
- Is door jammed?

Emergency lighting faulty

- Which lights are affected?
- Is it failing to turn off or not coming on?
- Is fire alarm ringing?

Communal lighting faulty

- Which lights are affected?
- Is it on all the time?
- Does it not come on at all?

Rubbish chute faulty

- What is wrong? (chute is blocked, broken etc)

Communal TV aerial faulty

- What is the nature of the problem?

Gutters and Down Pipes

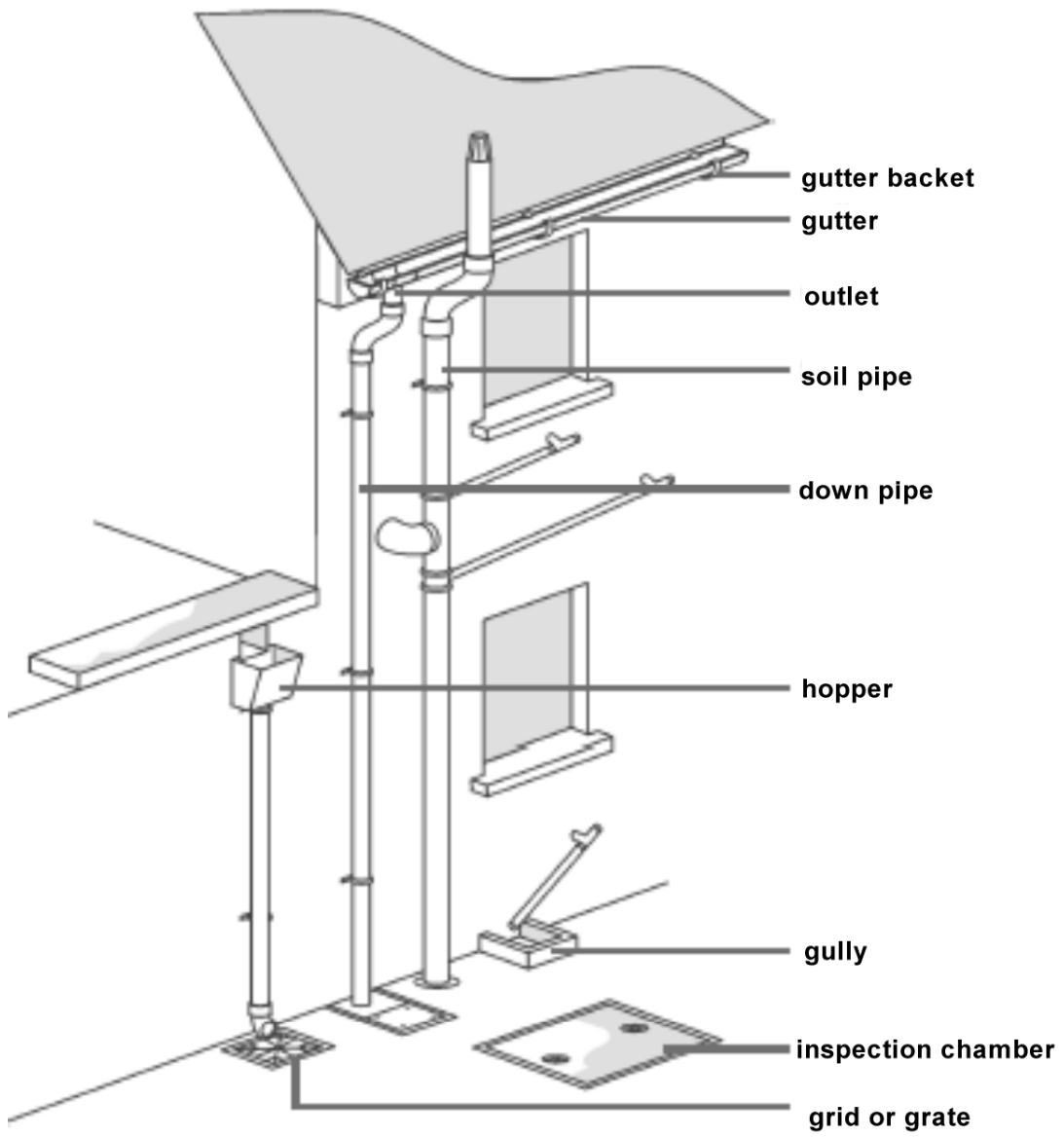

**back
inlet
gully**



**open
gully**

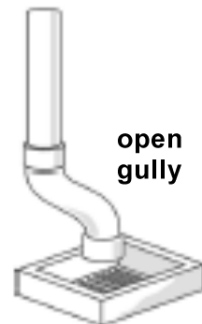

Gutters and Down Pipes

Before you contact us...

- If dangerous, put something over it to alert others to the danger.

- Try to clear any leaves or other rubbish yourself with a stick.

Tell us...

Manhole cover defective

- Where is it?
- What is the problem? (loose, broken or missing)
- What is it made of?
- Is it dangerous?

Manhole overflowing

- Where is it located?

Gully cover defective

- Where is it?
- What is the problem? (loose, broken or missing)
- Do you think it can be refixed or does it need to be replaced?
- What is it made of?
- What size is it?

Gutter overflowing

- Where is the overflow coming from? (gutter, hopper, pipe etc. See diagram on page 42)

Gully blocked

- What is blocking the gully?

Drains blocked

- What is blocking the drain?

Garden and Garage



Cothes Post



Rotary Drier

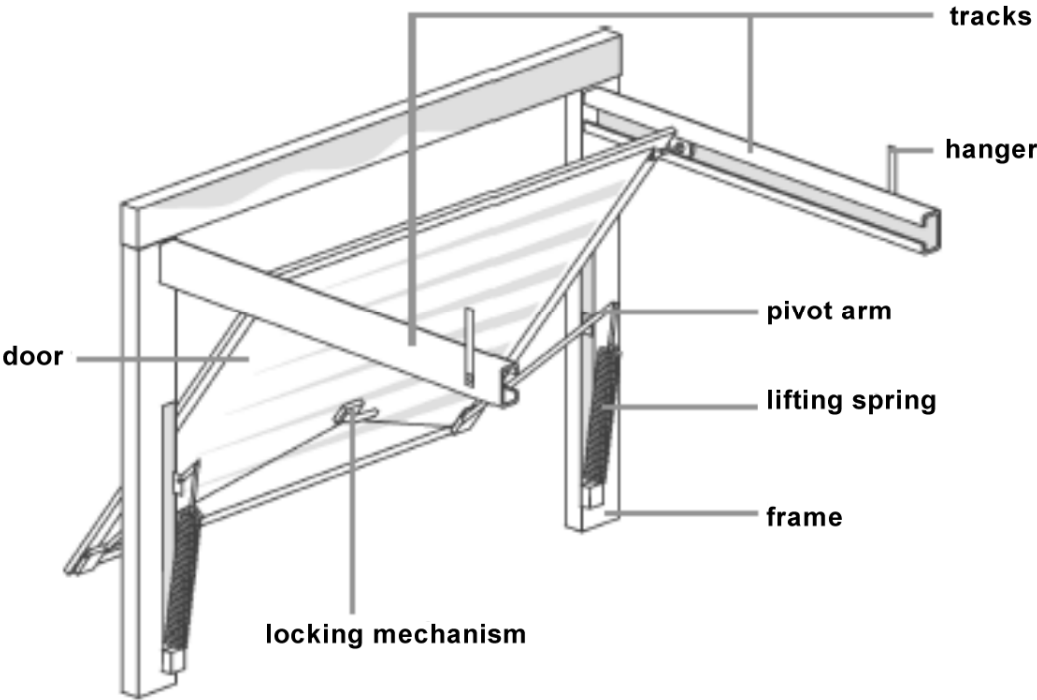

Before you contact us...

- Removal of rubbish is usually a tenant's responsibility

- Replacing a clothes line is usually a tenant's responsibility

Tell us...

Rubbish dumped in garden

- What sort of rubbish?
- Who put it there?
- Is it hazardous?

Clothes post broken

- What is it made of? (concrete or metal etc)
- How was it broken?

Clothes line broken or missing

- What type of clothes line is it?
- Is pulley or bracket broken?

Garage door faulty

- What type of garage door is it?
- What is door made from? (wood, metal etc.)
- What is the problem? (door or frame is loose, damaged off mechanism, lock is broken keys are lost etc)

Index

Basin (page 9)

Blocked
Damaged/broken
Tiles damaged
Plug chain required
Seal gone
Tap dripping/faulty
Tap loose
Water leaking

Bath (page 9)

Blocked
Damaged/broken
Tiles damaged
Plug chain required
Panel loose
Seal gone
Tap dripping/faulty
Tap loose
Water leaking

Boiler (central heating) faulty (page 9)

Clothes line (page 45)

Broken/stolen
Post broken

Cupboard (kitchen) damaged (page 5)

Door (internal) (page 29)

Damaged
Sticking/jammed
Latch damaged

Door (external) (page 31)

Draught
Frame damaged/rotten
Glass damaged/broken
Ironmongery (letterplate, handle)
Jammed
Lock not working
Rain coming in
Threshold damaged
Weatherboard damaged

Door entry faulty (page 41)

Downpipe/guttering faulty (page 43)

Drains blocked (page 43)

Electrics:none at all (page21)

Electrial appliance faulty (page 23)

Electrical fitting smoking (page 21)

Extractor fan faulty (page 25)

Fumes in room (page 27)

Garage door faulty (page 45)

Gully (page 43)

Blocked
Cover defective
Gutter overflowing

Heating (page 25)

Communal
Radiant/convactor
Storage

Hot water stopped (page 19)

Keys lost (page 35)

Leak

From bath/basin (page 9)
From kitchen sink (page 5)
From radiator (page 27)
From WC (page 15)

Lighting (page 21)

Failed
Fluorescent tube gone
Emergency) faulty
Communal) faulty

Locked out (page 35)

Manhole (page 43)

Cover broken
Overflowing

Plug socket failed (page 23)

Power: none at all (page 21)

Radiator

Leaking (page 27)
Not heating up (page 25)

Rubbish chute faulty (page 41)

Rubbish dumped in garden
(page 45)

Sealing strip gone

Around basin (page 11)
Around shower (page 13)
Around kitchen sink (page 7)

Shower (page 13)

Blocked
Cubicle door faulty
Curtain damaged
Hose broken
Not working
Seal gone around tray
Shower arm broken
Switch broken
Tray broken
Tiles damaged

Sink (kitchen)

Blocked (page 5)
Tap dripping (page 7)
Tap loose (page 7)
Unit leaking (page 5)

Smoke detector faulty (page 23)

Soil stack blocked (page 17)

Tap dripping/faulty on basin/bath
(page 11)

Tap loose on bath/basin (page 11)

Threshold damaged (page 31)

Tiles (wall) damaged

Bath/basin (page 11)
Kitchen sink (page 5)
Shower (page 15)

TV aerial (communal) faulty
(page 41)

Washing machine blocked
(page 7)

Waste blocked (bath/basin)
(page 9)

Water

Leaking from bath/basin (page 9)

WC

Blocked (page 17)
Leaking (page 15)
Flush not working (page 15)
Overflow running (page 17)
Seat damaged (page 17)

Soil stack blocked (page 17)

Window

Frame jammed/sticking (page 37)
Glass damaged/broken (page 37)
Ironmongery (handle, fastener etc)
(page 39)

Weatherboard damaged (page 33)

Contact Information

Health and Housing Services Council Housing

Postal address:

PO Box 4, Town Hall, LANCASTER, LA1 1QR

Office:

38 Cable Street, LANCASTER, LA1 1HH

Telephone:

01524 582929

Email:

councilhousing@lancaster.gov.uk

Web site:

www.lancaster.gov.uk

Our office hours are 9.00 am to 5.00 pm weekdays
(10.00 am to 5.00 pm Wednesdays)

When the office is closed, if there is an emergency,
ring the Council's Emergency Call Centre,
which is open 24 hours a day, 365 days a year.

The number to call is: 01524 67099

Calls may be recorded to help improve
our standard of service and accuracy of information



A053b KH 11/11